



Groundreach Workshop
Zürich, Switzerland, May 23, 2008



**GSHP at the Eastern and Western
end of the EU :
Glucksman art gallery in Cork, Ireland, and
Porsche showroom in Bucharest, Romania**

Dr. Burkhard Sanner

European Geothermal Energy Council, Brussels

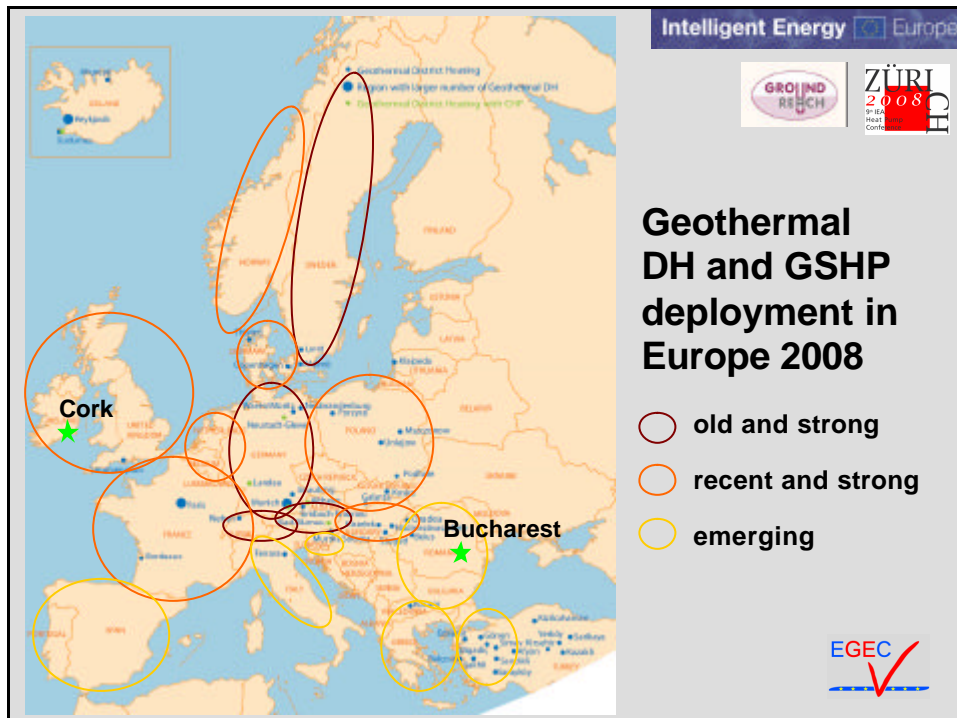

Lewis Glucksman Art Gallery University College Cork, IE



The gallery is a fine example of modern architecture,
providing sufficient space on a small footprint



Most photos and graphs
Glucksman gallery:
Kevin o'Regan, UCC,
and Dunstar Ltd.

European Geothermal Energy Council



Lewis Glucksman Art Gallery University College Cork, IE



The gallery is a fine example of modern architecture,
providing sufficient space on a small footprint

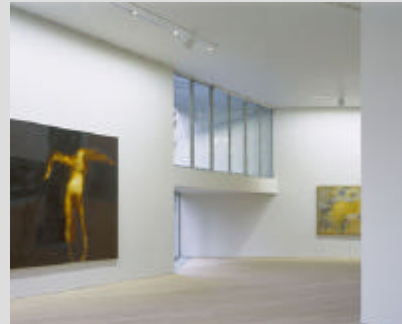

European Geothermal Energy Council



Lewis Glucksman Art Gallery University College Cork, IE



The gallery offers:

- 2350m² of room
- 4 Exhibition spaces
- Multifunction rooms
- Lecture facilities
- Café
- Gallery Store in the basement

The gallery requires:

- 190 kW heating
- 130 kW cooling
- Critical exhibition and storage space requires humidity control,
- Dehumidification requires that heating and cooling be supplied simultaneously to Close Control areas.



European Geothermal Energy Council



Lewis Glucksman Art Gallery University College Cork, IE



Dehumidification, conventional vs GSHP

- Conventional, you pay twice: to cool, and to reheat; the heat from the chiller is dumped
- The Heat Pump uses the extracted heat as a renewable resource and heats the air to the required temperature

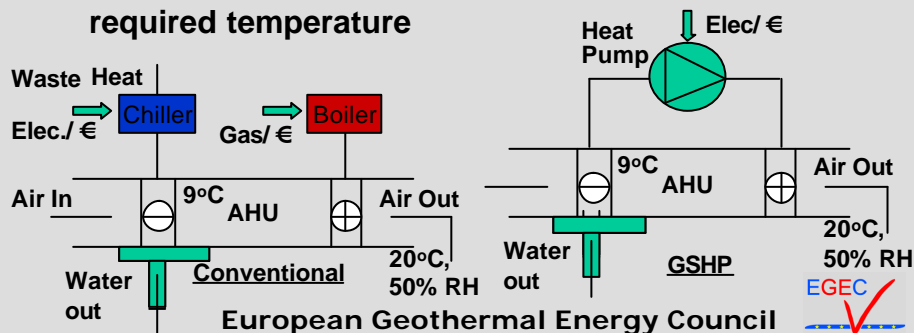

**Lewis Glucksman Art Gallery
University College Cork, IE**

**200 kW open loop (groundwater)
heat pump for precise temperature
($19 \pm 1/2^\circ\text{C}$) and humidity control**



Wellhead under construction



European Geothermal Energy Council



Intelligent Energy Europe



**Lewis Glucksman Art Gallery
University College Cork, IE**

Very specific aquifer situation:

- “buried valley”**
- High permeability
 - Well defined boundary
 - One of those underlying most of Cork



Buried Valley just upstream of Cork



European Geothermal Energy Council



Intelligent Energy Europe



Lewis Glucksman Art Gallery University College Cork, IE



200 kW open loop (groundwater)
heat pump for precise temperature
($19 \pm 1/2^\circ\text{C}$) and humidity control



Heat Pump York YCWM, using R407C
2 peak boilers (gas)

European Geothermal Energy Council



Close Control Gallery: 20°C ; RH $50\% \pm 5\%$,
Base. Close Control Store: 20°C ; RH $50\% \pm 2.5$,

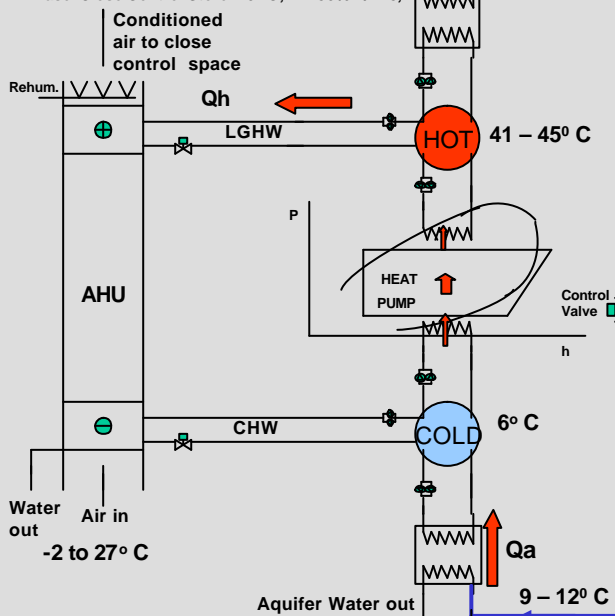

Geothermal Heating

Heat Pumps Enabled
Heat Balance $Q_a = Q_h$
Heat input controlled by
speed of Submersible
Pumps.

COP = 4

Water in from Aquifer, $9-12^\circ\text{C}$

Submersible
Pumps
(Inverter
Controlled)

Aquifer



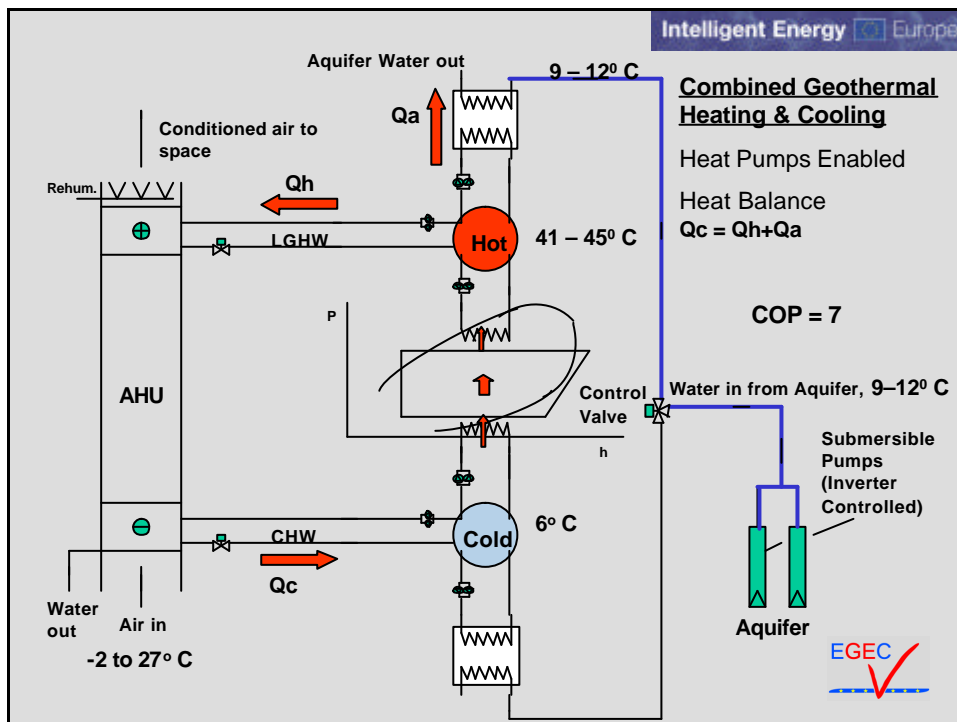
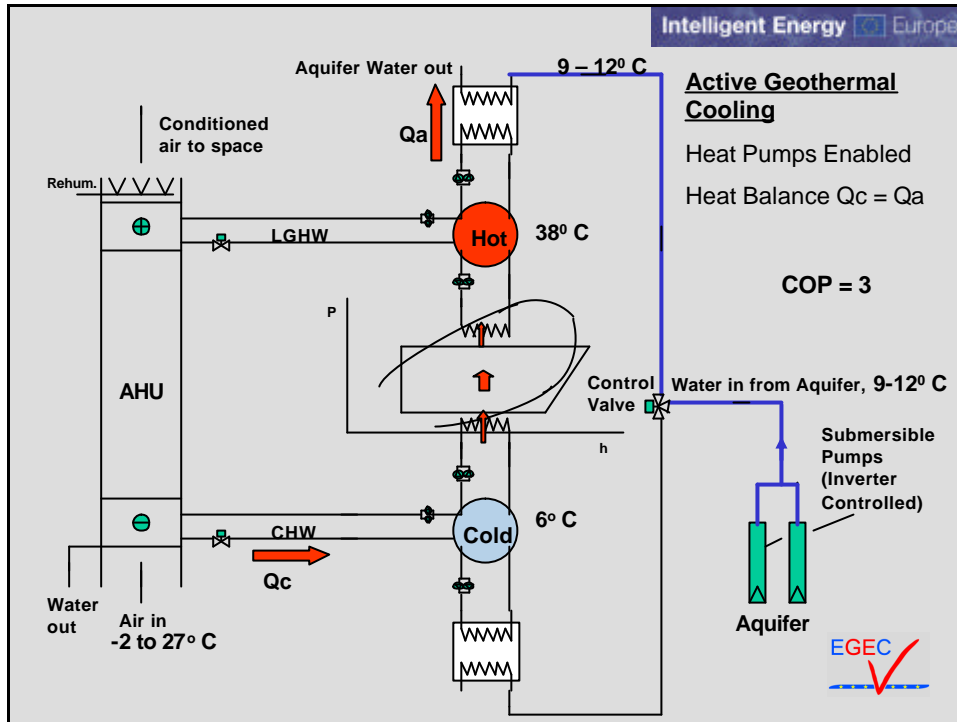

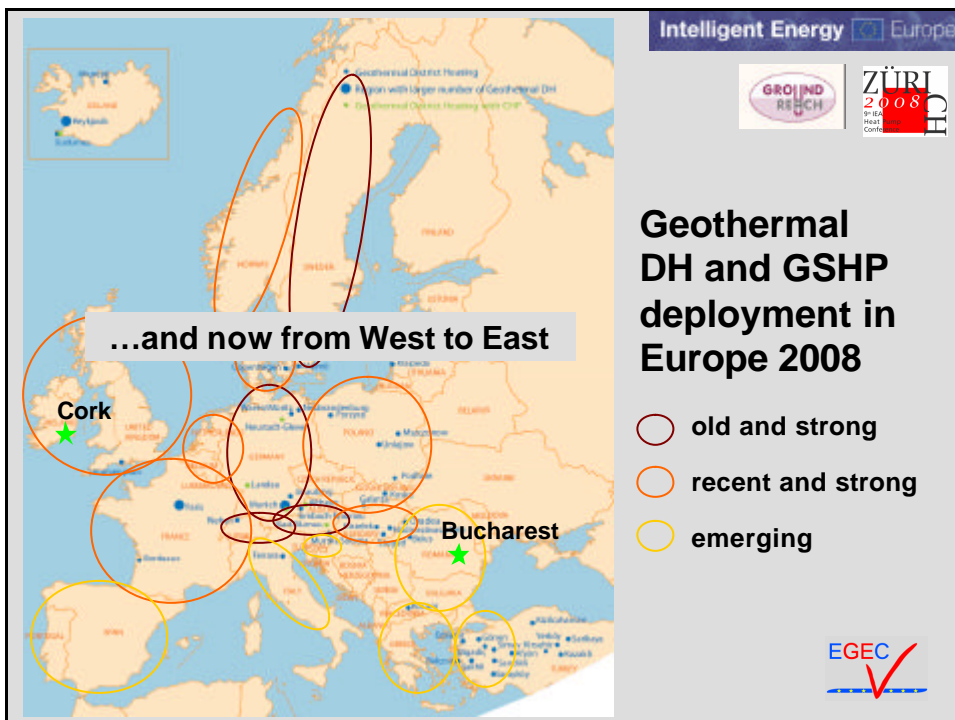
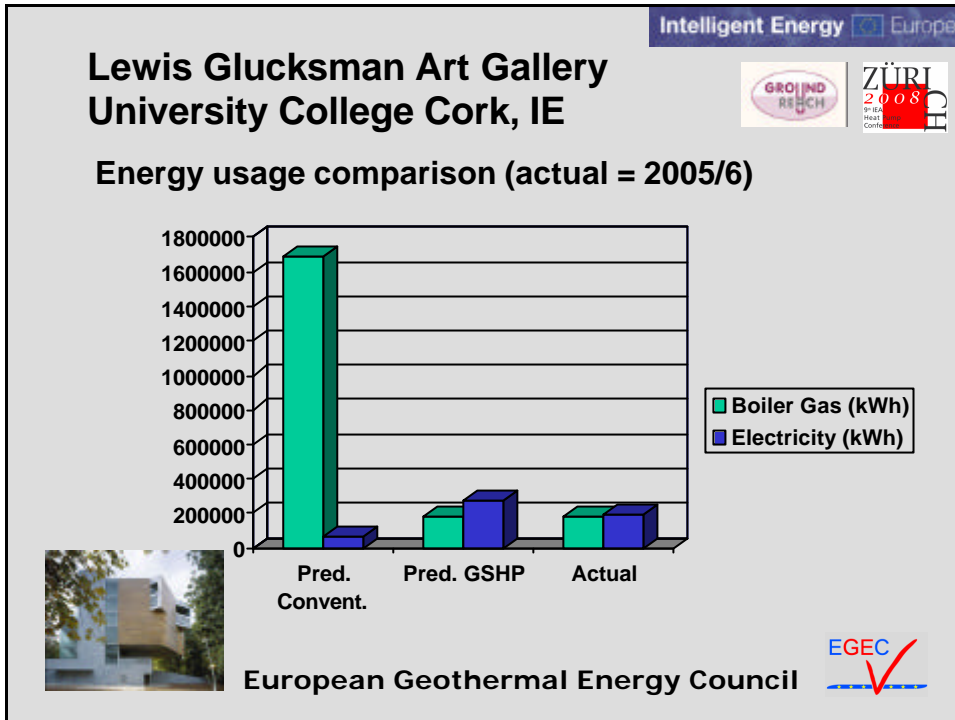

PORSCHE Bucharest West 2 – Showroom and Service, RO



Showroom, service workshops, and offices for Audi and SEAT cars, constructed 2006

Project developed by



Member of EGEC

Photos and graphs
Porsche Showroom:
Doina Cucueteanu, ASA,
and Radu Polizu, RGS



European Geothermal Energy Council



PORSCHE Bucharest West 2 – Showroom and Service, RO



Metallic construction - total unfolded area of 3.507 m², structured in four distinctive parts:

- SEAT showroom of 360 m², made of steel and glass
- AUDI showroom of 795 m² (650 m² area of car presentation; 145 m² - office area, on two levels)
- Middle section of metal and glass of 421 m² (links the two showrooms)
- Workshop of 1931 m², with thermally insulated lateral walls



European Geothermal Energy Council



PORSCHE Bucharest West 2 – Showroom and Service, RO



Metallic construction - total unfolded area of 3.507 m²

Spec. thermal loss: 0,209 W/(m³K)
Heating load: 308 kW_{th}
Cooling load: 313 kW_{th}
DHW: 200 kWh/day
Fresh air flow: 3000 m³/h



European Geothermal Energy Council



PORSCHE Bucharest West 2 – Showroom and Service, RO



Building equipment:

- 17 water-to-water and 12 water-to-air heat pumps (Florida Heat Pump), using R410A
- 750 m² of special surfaces of under-floor piping system for heating and cooling
- Ventilation channels connected to several water-to-air heat pumps, located mainly in the false ceilings of the building



European Geothermal Energy Council



PORSCHE Bucharest West 2 – Showroom and Service, RO

Ground side equipment:

- 128 vertical borehole heat exchanger
- each 70–75 m deep
- under a field of 3.500 m²



European Geothermal Energy Council

Intelligent Energy Europe

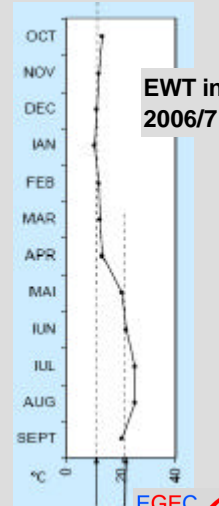

PORSCHE Bucharest West 2 – Showroom and Service, RO

System performance:

- 475 MWh for heating (and hot water) annually
- 393 MWh for cooling annually
- For the time period under survey (2006/7), the coefficient of performance of the HVAC system was higher than COP=4,8 (see graph to the right)
- H&C is 100 % geothermal



European Geothermal Energy Council

Intelligent Energy Europe

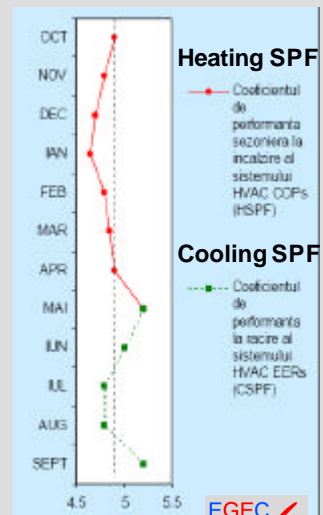

PORSCHE Bucharest West 2 – Showroom and Service, RO



Comparison with conventional system:

- PBW1 is another Porsche facility for SKODA and VOLKSWAGEN cars with classic HVAC system and 5231 m² (similar construction in very close area, with identic solar orientation, same functions, commissioned in January 2006).
- PBW1 uses natural gas for heat and hot water, and last generation Air-to-Air VRV (Variable Refrigerant Volume) multisplit systems for ventilating and air conditioning during winter and summer.



European Geothermal Energy Council



PORSCHE Bucharest West 2 – Showroom and Service, RO



CHETUIELI SPECIFICE LUNARE SI ANUALE DE EXPLOATARE A INSTALATIILOR HVAC
PORSCHE BUCURESTI VEST 1 - PORSCHE BUCURESTI VEST 2
CONFORM FACTURILOR LUNARE DE UTILITATI

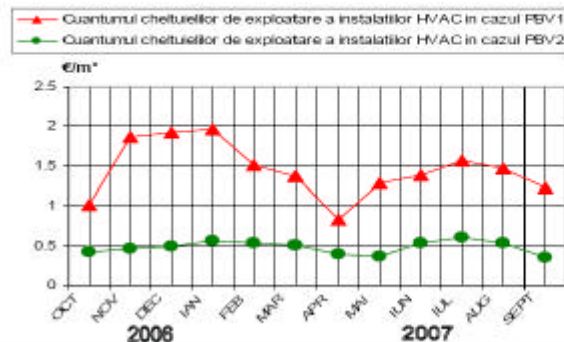

The specific HVAC annual costs

PBW1 – 17.39 Euro/sqm

PBW2 – 5.8 Euro/sqm

The specific costs are calculated at the average prices for electricity and natural gas in the survey period of time in Romania:

Electricity

72.86 Euro/MWh

Natural gas

316.8 Euro / 1000 m³N



European Geothermal Energy Council



PORSCHE Bucharest West 2 – Showroom and Service, RO

**GSHP
advances
building to
category C
of energy
efficiency
law!**

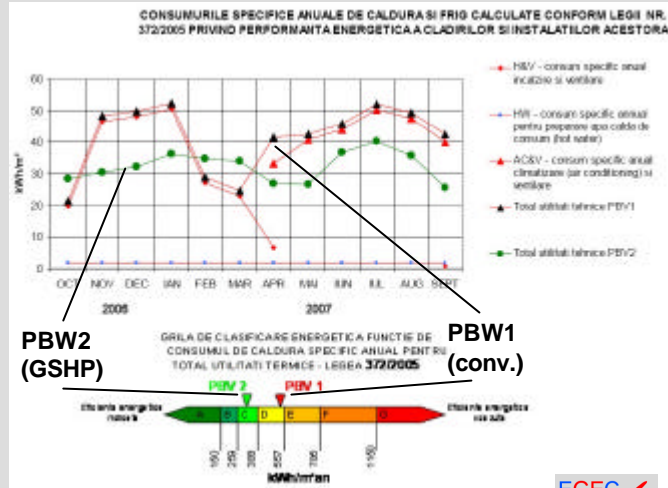

European Geothermal Energy Council



PORSCHE Bucharest West 2 – Showroom and Service, RO

Conclusions:

- If properly designed, implemented and used, the GSHP HVAC system brings important economical and ecological advantages, compared to the classic HVAC solution
- The consumption of resources for heating, ventilation and hot water in winter season in the GSHP HVAC system is 5 times smaller, and
- the CO₂ pollution in GSHP HVAC system is 10 times smaller than in classic system with natural gas



European Geothermal Energy Council





For more information:

www.egec.org

www.groundreach.eu



***Thank you for your
attention!***

European Geothermal Energy Council

